

SECTION A-A
SCALE 1 : 4

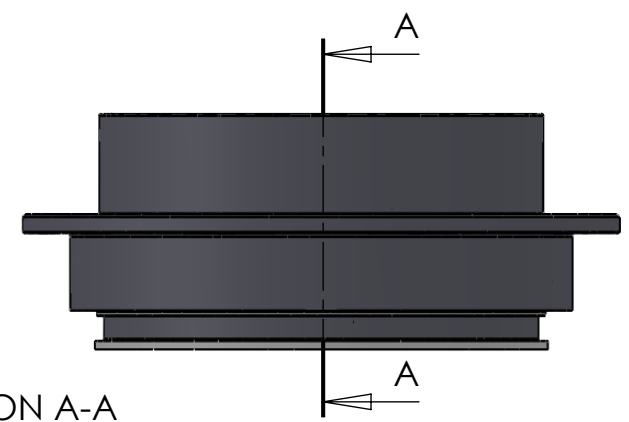

ITEM NO.	PART NUMBER	PART NAME	QTY.
1	M33-135	Outer house 4SF180-4SF199	1
2	M11-115	Ball 4SF180-4SF199	1
3	O-ring	ø230 x 2.5	1
4	M03-755	Delrin Lockring ø218,5 x ø201 x 2,75mm	2
5	M05-382	L-ring ø190 x ø215 x 7,5mm	2
6	M01-372	Roller ø12.5 x 57mm	50
7	M35-131	Inner house 4SF190-4SF199	1
8	O-ring	ø220 x 2.5	1
9	M09-150	Alu lockring ø225.5 x ø237.5	1
10	M07-247-B	Washer, delrin ø195 x ø230 x 4,5mm	1

DWG NR / NAME: 4SF190 / S-A top roller bearing				BATCH NR:		
PROJECT: Shaft Ø190mm, max working load 10800kg				REKV.NR / ORDRE NR:		
DATE: 20-01-2011	NAME: JR	SCALE / PAPER: 1:6 / A4	MATERIAL: g	LOCATION:	ORDRE DATO:	JEFA MARINE A/S NIMBUSVEJ 2 2670 GREVE. DENMARK Tlf: +45 4615 5210 & Fax: +45 46155208 Email: info@jefa.com www.jefa.com
MODIFY DATE: /			WEIGHT: g	REV:	LEV.DATO:	