

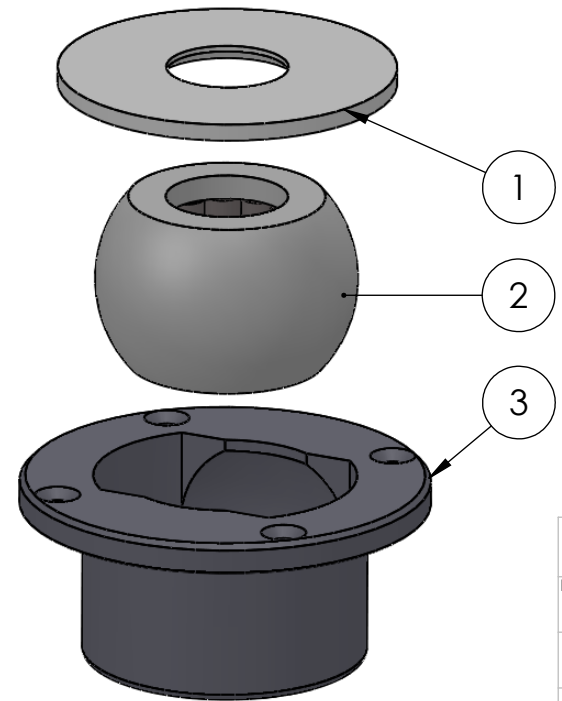

SECTION A-A  
SCALE 1 : 1



ITEM NO.	PART NUMBER	PART NAME	QTY.
1	M07-099	Washer $\phi 32,5 \times \phi 90 \times 4,5\text{mm}$	1
2	M13-104-32	Ball with Rollers for $\phi 32\text{mm}$	1
3	M51-085	House for 5T030-5T045	1

DWG NR / NAME: <b>5T032 / S-A top roller bearing <math>\phi 32\text{mm}</math></b>				BATCH NR:		 <b>JEFA MARINE A/S</b> NIMBUSVEJ 2 2670 GREVE, DENMARK Tlf: +45 4615 5210 & Fax: +45 46155208 Email: info@jefa.com www.jefa.com
PROJECT: Shaft $\phi 32\text{mm}$ , max working load 1000-1400kg						
DATE: 08.01.2016	NAME: JR	SCALE / PAPER: 1:2 / A4	MATERIAL: WEIGHT: g	LOCATION:	REKV.NR / ORDRE NR:	
MODIFY DATE: : /				ORDRE DATO:	LEV.DATO:	