

SECTION A-A
SCALE 1 : 1.2

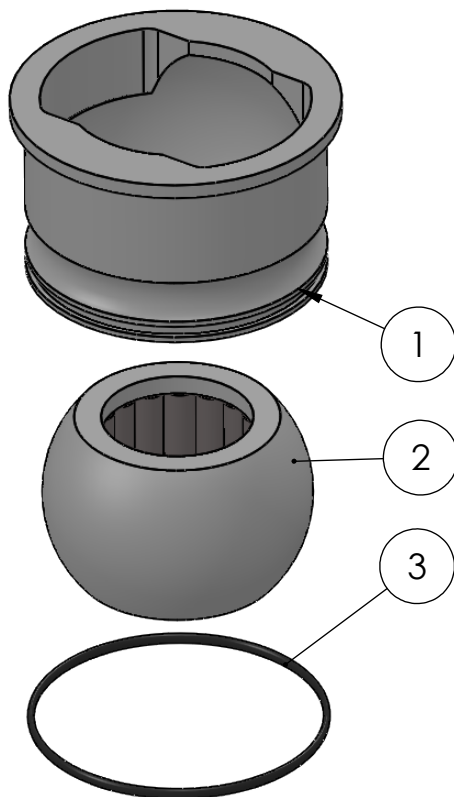
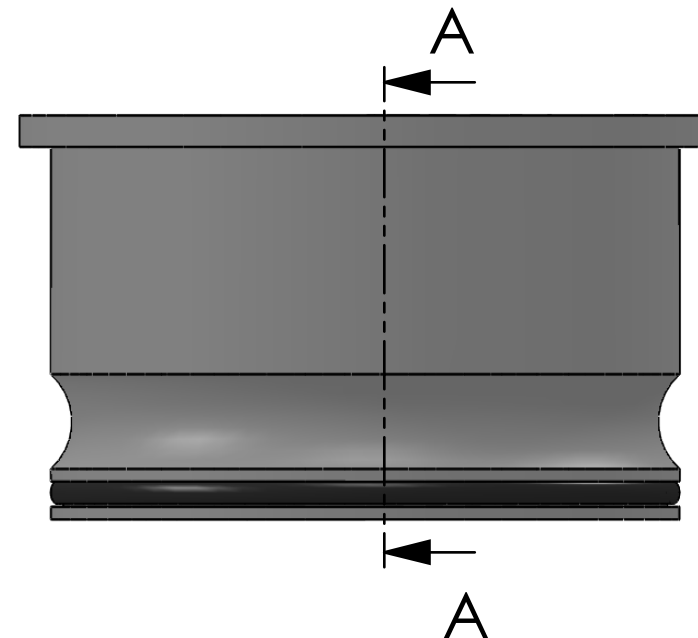

ITEM NO.	PART NUMBER	PART NAME	QTY.
1	M48-105	House ø100mm for ø90mm Ball	1
2	M13-160-49	Ball with rollers for Ø49mm	1
3	O-ring	ø90 x 2,5mm	1

DWG NR / NAME: 6BF100049 / S-A Top Roller bearing				BATCH NR:	
PROJECT: Shaft Ø49mm				REKV.NR / ORDRE NR:	
DATE: 12.09.2016	NAME: JR	SCALE / PAPER: 1:2 / A4	MATERIAL: PETP	LOCATION:	ORDRE DATO:
MODIFY DATE: : /			WEIGHT: g	REV:	LEV.DATO:

Jefa Rudder
S Y S T E M S

JEFA MARINE A/S
NIMBUSVEJ 2
2670 GREVE, DENMARK
Tlf: +45 4615 5210 & Fax: +45 46155208
Email: info@jefa.com www.jefa.com