

SECTION A-A
SCALE 1 : 1.2

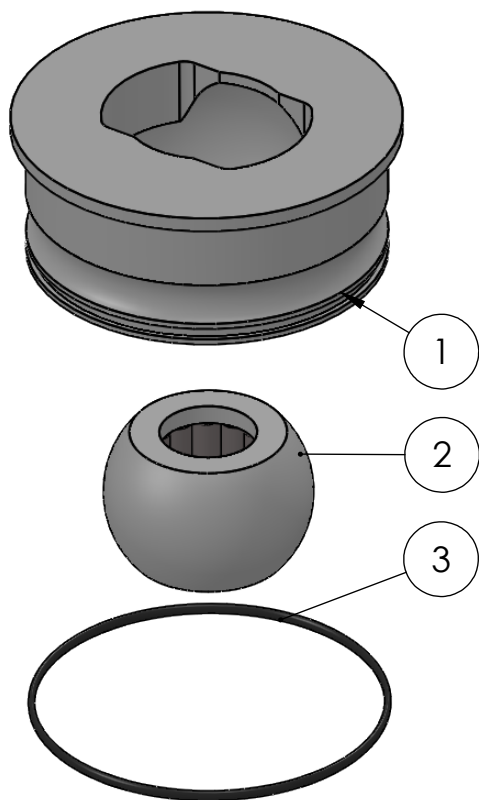

ITEM NO.	PART NUMBER	PART NAME	QTY.
1	M48-142	House ø120mm for ø70mm Ball	1
2	M13-104-32	Ball with Rollers for Ø32mm	1
3	O-ring	ø110 x 2.5	1

DWG NR / NAME: **6BF120032 / S-A Top Roller bearing**

PROJECT:
Shaft Ø32mm

DATE:
12.09.2016

NAME:
JR

SCALE / PAPER:
1:2,5 / A4

MATERIAL: PETP
WEIGHT: g

LOCATION:
REV:

BATCH NR:

REKV.NR / ORDRE NR:

ORDRE DATO:

LEV.DATO:

Jefa Rudder
SYSTEMS

JEFA MARINE A/S
NIMBUSVEJ 2
2670 GREVE. DENMARK

Tlf: +45 4615 5210 & Fax: +45 46155208
Email: info@jefa.com www.jefa.com

MODIFY DATE:
: /