

SECTION A-A

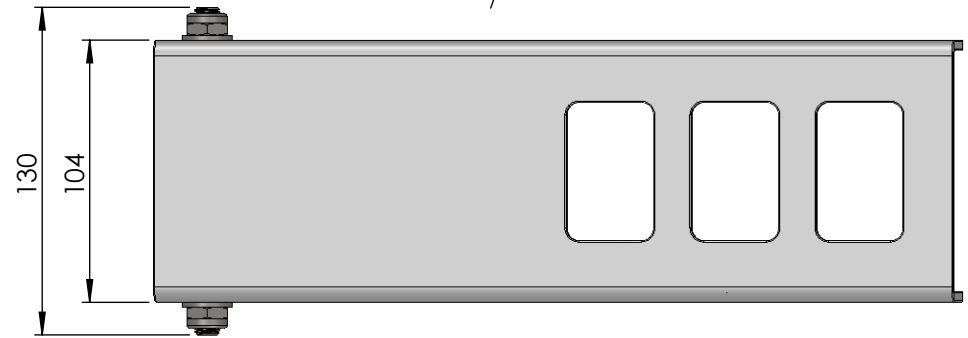
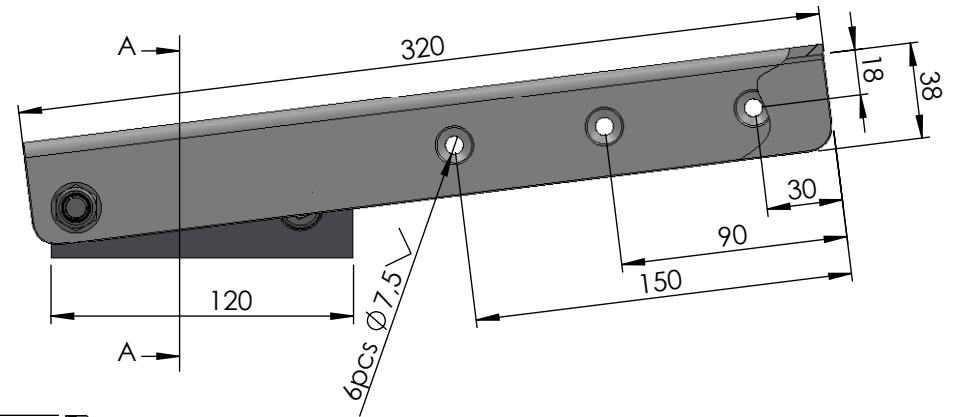

ITEM NO.	PART NUMBER	PART NAME	QTY.
1	M56-135	$\phi 70$ mm klamp block for tillerhead	1
2	M56-160	U-profil for 47070 tillerhead	1
3	M56-201	$\phi 12$ mm bush for tillerheads	2
4	M56-204	Washer for tillerheads $\phi 12 \times \phi 25 \times 1$ mm	2
5	M56-220	Pinbolt for tillerhead 47070 M10x130mm	1
6	DIN10511-10	Torque nut with thin insert M10	2
7	DIN126-10	Plain washer $\phi 11 \times \phi 20$	2
8	DIN24035-10	Thin nut M10	2
9	DIN912-10x40	Socket head cap screw M10x40	1
10	DIN912-08x80	Socket head cap screw M8x80	1
11	DIN916-10x30	Socket set screw with cup point M10x30	2

DWG NR / NAME:

47070 / Tillerhead

BATCH NR:

PROJECT:

Shaft  $\phi 70$ , black anodized head

REKV.NR / ORDRE NR:

DATE:

14-04-2009

NAME:

KJ

SCALE / PAPER:

1:3 / A4

MATERIAL:

WEIGHT: g

LOCATION:

REV:

ORDRE DATO:

LEV.DATO:

MODIFY DATE:

: /

*Jefa Rudder*  
S Y S T E M S

JEFA MARINE A/S  
NIMBUSVEJ 2  
2670 GREVE. DENMARK

Tlf: +45 4615 5210 & Fax: +45 46155208  
Email: info@jefa.com www.jefa.com