

ITEM NO.	Jefa No.	Description	QTY.
1	WP900	Pendular pedestal	1
2	WHS0900L	Stainless steel wheel, 900mm with gray hide cover	1
3	SP-SP139	Brake spinner, short	1
4	UJ10	Universal joint	2
5	TTCLAMP	Clamp for toq-tubes	1
6	BRG10-50	Bevel reduction gearbox	1
7	DL070080-30	Draglink 700-800mm ø30	2
8	TLJPIN16	Pin for ø16mm hole	1
9	TLJPIND	Pin for twin mount on tiller tever	1
10	TLL050	Tiller arm light, bore and key see drawing	2
11	5T044	Self-aligning top roller bearing ø44mm	2
12	46044	44mm locking ring	2
13	TU080250	Alu tube ø80 x ø76 x 250mm	2
14	5BT051	Conical bottom bearing	2

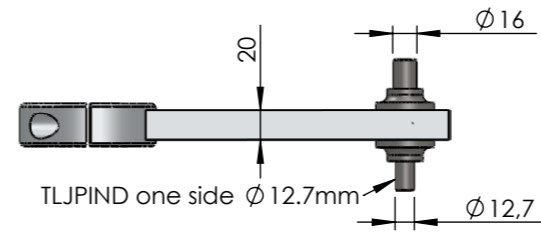
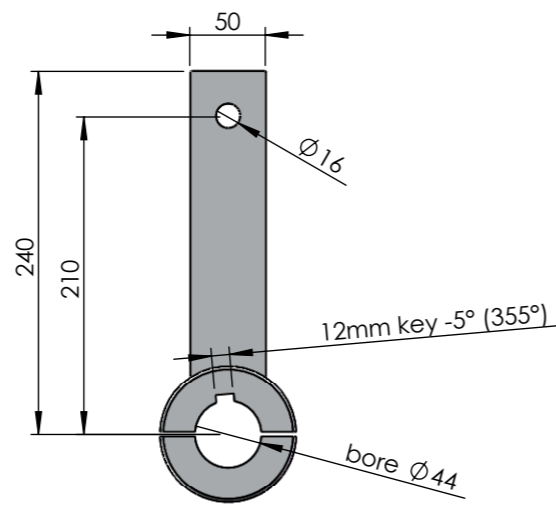
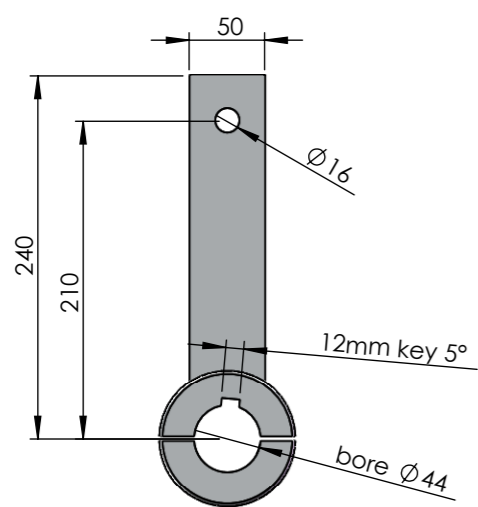

Project: **Elan 310 wheel steered**

Scale: 1:20 Date: 31/08-2009

Drawn by: KJ

Jefa Rudder & Jefa Steering SYSTEMS

JEFA MARINE A/S
Nimbusvej 2
2670 Greve, Denmark
Phone: +45 4615 5210 & Fax: +45 4615 5208
Email: info@jefa.com Homepage: www.jefa.com

JEFA STEERING ApS
Agenavej 43
2670 Greve, Denmark
Phone: +45 4615 5210 & Fax: +45 4615 5208
Email: info@jefa.com Homepage: www.jefa.com